

# KHD



KHD

The Aston Seals KHD is a double acting piston seal for high pressure operation and is composed of:

- A dynamic seal element which assures exceptional low friction and high speed performance, high compatibility with nearly all media due to the chemical resistance which exceeds that of all other thermoplastics and elastomers
  - A rubber element with low permanent deformation as energizing component on the static side
  - Two backup rings which offset large gaps or structural deflections without extrusion and assure high longevity
- Low static and dynamic friction

- No tendency of stick-slip
- Space-saving construction and simple groove design
- High resistance against extrusion
- Extended service life

## MATERIAL

	① <b>Type</b>	Polytetrafluoroethylene PTFE + Bronze
	<b>Designation</b>	SEALFLON + Bronze
	② <b>Type</b>	Nitril Rubber NBR
	<b>Designation</b>	RUBSEAL 80
	<b>Hardness</b>	80 °ShA
	③ <b>Type</b>	Acetal resin
	<b>Designation</b>	BEARITE

## FIELD OF APPLICATION

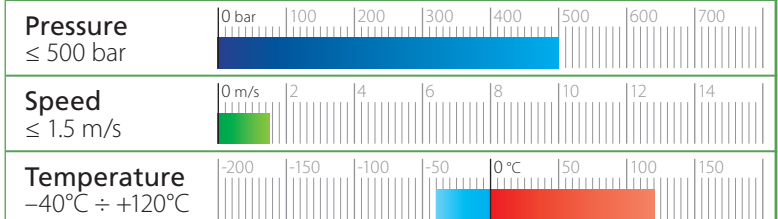

**Fluids** Hydraulic oils (mineral oil based)  
For other fluids contact our technical department

## SURFACE ROUGHNESS

<b>Dynamic surface</b>	Ra ≤ 0.3 µm	Rt ≤ 2.5 µm
<b>Static surface</b>	Ra ≤ 1.6 µm	Rt ≤ 6.3 µm

## GAP DIMENSION "g"

The largest gap dimension appearing in operation on the non-pressurised side:

300 bar	1.0 mm	500 bar	0.6 mm
---------	--------	---------	--------

NB: for the Gap calculation, it is necessary to consider the elastic deformation of metal elements under pressure loads.

## LEAD-IN CHAMFERS

d	Smin
0 ÷ 60	4.5 mm
70 ÷ 120	5.0 mm
125 ÷ 200	6.5 mm

To avoid damaging the sealing lips during installation, housing must have rounded chamfers. Sharp edges and burrs within the installation area of the seal must be removed.

The above data are maximum values, they may be maintained for short periods and can not be used at the same time simultaneously.

# KHD

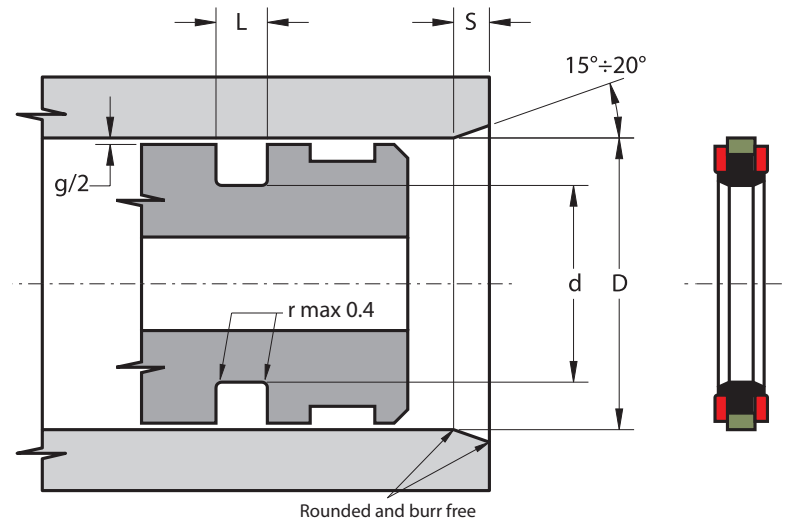

Part.	D <sup>H9</sup>	d <sup>±0.1</sup>	L <sup>+0.2</sup>
KHD 50 36 9	50	36	9
KHD 55 41 9	55	41	9
KHD 60 46 9	60	46	9
KHD 65 50 11	65	50	11
KHD 70 55 11	70	55	11
KHD 75 60 11	75	60	11
KHD 80 65 11	80	65	11
KHD 85 70 11	85	70	11
KHD 90 75 11	90	75	11
KHD 95 80 11	95	80	11
KHD 100 85 12.5	100	85	12.5
KHD 105 90 12.5	105	90	12.5
KHD 110 95 12.5	110	95	12.5
KHD 115 100 12.5	115	100	12.5

Part.	D <sup>H9</sup>	d <sup>±0.1</sup>	L <sup>+0.2</sup>
KHD 120 105 12.5	120	105	12.5
KHD 125 102 16	125	102	16
KHD 130 107 16	130	107	16
KHD 135 112 16	135	112	16
KHD 140 117 16	140	117	16
KHD 145 122 16	145	122	16
KHD 150 127 16	150	127	16
KHD 160 137 16	160	137	16
KHD 165 142 16	165	142	16
KHD 170 147 16	170	147	16
KHD 180 157 16	180	157	16
KHD 185 162 16	185	162	16
KHD 200 177 16	200	177	16
KHD 225 202 16	225	202	16