

### Features

1. The data of power and final temperature are valid for the standard voltages 24VDC and 230VAC; the power consumption may be higher at different nominal voltages.
2. Function is warranted at max. ambient temperature, max. voltage change and operating temperature.
3. The data of final temperature is valid for thermoplastic valve bodies and thermoplastic encapsulated coils. The temperature will be approximately 10-20K higher if the bodies are manifold.
4. This will cause a reduction of the magnetic force.
5. For additional information see German standard "Specification for Electronic Devices" DIN VDE 0580 or folder 1.4.0.0.



### Order code

Voltage	Order code	Remarks
24VAC	SA91330DXNN	Option (17.6VA)
48VAC	SA41330DXSN	Option (22VA)
12VDC	SD71330DQNN	Option (15W)
24VDC	SD91330DQSN	Standard (15W)
110VAC	SA11330DXSN	Standard (17.6VA)
220VAC	SA21330DXSN	Standard (18.1VA)
240VAC	SA81330DXXN	Option (22VA)

\*Special voltage on your request

### Specifications

Coil width	30mm
Voltage tolerance	±10%
Duty cycle	100% ED
Ambient temperature	-20°C ~ 50°C
Isolation class of material	F (according to Din VDE0580)
Degree of protection	IP65 (according to EN60529)
Moulding material	Thermoplastic (PA, PPS)
Rated power DC	15W
Rated power AC (60Hz)	16VA
Rated power AC (50Hz)	19VA
Type	DIN 43650A (ISO4400)

### Dimensions

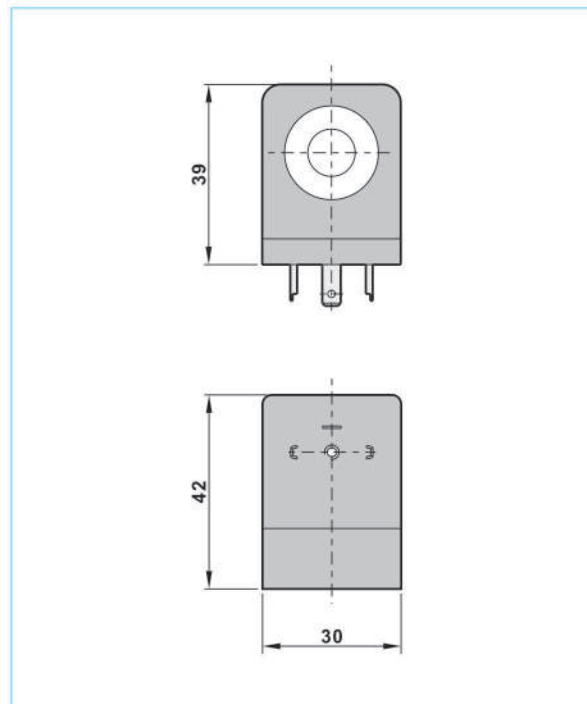

### Coil nuts

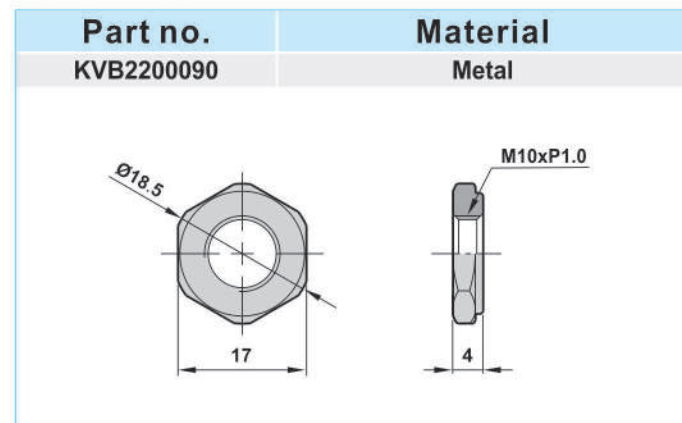

### Features

1. The data of power and final temperature are valid for the standard voltages; the power consumption may be higher at different nominal voltages.
2. Function is warranted at max. ambient temperature and operating temperature.
3. The data of final temperature is valid for thermoplastic valve bodies and thermoplastic encapsulated coils. The temperature will be approximately 10-20K higher if arrangement devices in modular design, and this will cause a reduction of the magnetic force.
4. For additional information see German standard "Specification for Electronic Devices" DIN VDE 0580.



### Order code

Voltage	Order code	Remarks
24VDC	SD91336DTNN	18.5W
110VAC	SA11336DZNN	50Hz 27.5VA
220VAC	SA21336DZNN	50Hz 25.5VA

### Specifications

Coil width	36mm
Voltage tolerance	±10%
Duty cycle	100% ED
Ambient temperature	-20°C ~ 50°C
Isolation class of material	F (according to Din VDE0580)
Degree of protection	IP65 (according to EN60529)
Moulding material DC	Thermoplastic (PA, PPS)
Moulding material AC	Thermoset Resin

### Dimensions

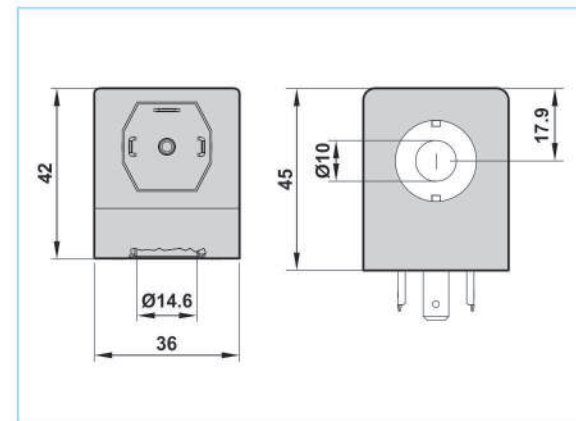

### Coil nuts

