

Applicable cylinder

1. Applicable to cylinder IC, ICL, TC, STC, PC, PCL, PMA, PMAL, GC series.
2. Wire length: 1M,2M,3M.



Specifications

Model	AL-20R	AL-20N	AL-20P
Switching logic	SPST Normally open	Solid state output, Normally open	
Output	Reed switch	NPN current sinking	PNP current sourcing
Lead wire type	Horizontal		
Load voltage	5~240 VDC/AC	5~28 VDC	
Load current	100mA Max.	200mA Max.	
Switching rating	10W Max.	6W Max.	
Current consumption	---	20mA Max. @24V	18mA Max. @24V
Voltage drop	2.5V Max. @40mA DC	0.5V Max. @200mA(Resistive load)	
Leakage current	---	0.01mA Max.	
Frequency	200Hz	1000Hz	
Shock	30G	50G	
Vibration	90m/s ² (9G) Double amplitude 1.5mm		
Insulation resistant	DC 500V 100MΩ (Lead wire to case)		
Withstand voltage	AC 1000V (50/60Hz) 1 minute (Lead wire to case)		
CE & Protection IP	EN60947-5-2 IEC529 IP67 (NEMA6)		
Indicator	Red LED	Green LED	
Cable	4.0 φ, 2C, Gray PVC	4.0 φ, 3C, Black PVC	
Temperature range	-10℃ ~ 70℃		
Protection circuit	---	Reverse polarity, short circuit, surge suppression	
Wiring	2Wire	3Wire	
Sensor circuit diagram			

Dimensions

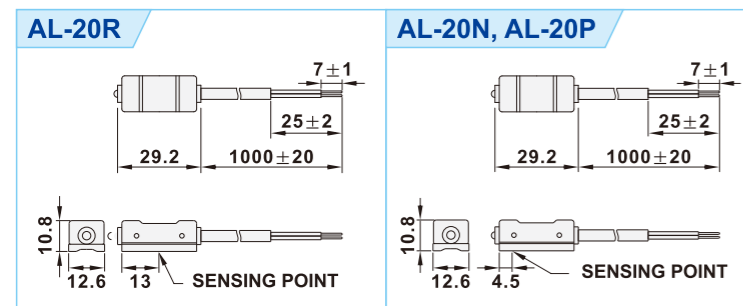

Mounting

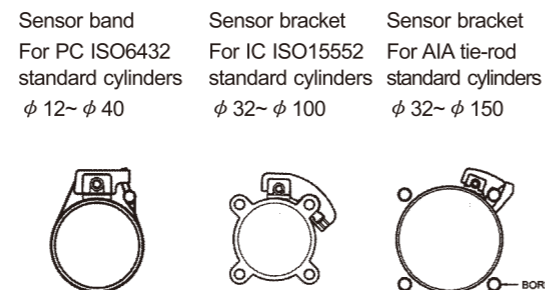

Note

1. Measure standard target: φ 15.5 x φ 8.5 x t5(Anisotropy Rubber Magnet)
2. Sin wave/X.Y.Z 3 Dimensions/3 times each direction/ 11mS Each time.
3. Double amplitude 1.5mm/10 Hz~55Hz~10Hz(Sweep 1min)/X.Y.Z 3 Dimensions/ 1 Hour Each time.

Applicable cylinder

1. Applicable to cylinder IC, ICL, TC, STC, PC, PCL, PMA, PMAL, GC series.
2. Wire length: 1M,2M,3M.



Specifications

Model	AL-21R	AL-21N	AL-21P
Switching logic	SPST Normally open	Solid state output, Normally open	
Output	Reed switch	NPN current sinking	PNP current sourcing
Lead wire type	Horizontal		
Load voltage	5~240 VDC/AC	5~28 VDC	
Load current	100mA Max.	200mA Max.	
Switching rating	10W Max.	6W Max.	
Current consumption	---	20mA Max. @24V	18mA Max. @24V
Voltage drop	2.5V Max. @40mA DC	0.5V Max. @200mA(Resistive load)	
Leakage current	---	0.01mA Max.	
Frequency	200Hz	1000Hz	
Shock	30G	50G	
Vibration	90m/s ² (9G) Double amplitude 1.5mm		
Insulation resistant	DC 500V 100MΩ (Lead wire to case)		
Withstand voltage	AC 1000V (50/60Hz) 1 minute (Lead wire to case)		
CE & Protection IP	EN60947-5-2 IEC529 IP67 (NEMA6)		
Indicator	Red LED	Green LED	
Cable	4.0 φ, 2C, Gray PVC	4.0 φ, 3C, Black PVC	
Temperature range	-10℃ ~ 70℃		
Protection circuit	---	Reverse polarity, short circuit, surge suppression	
Wiring	2Wire	3Wire	
Sensor circuit diagram			

Dimensions

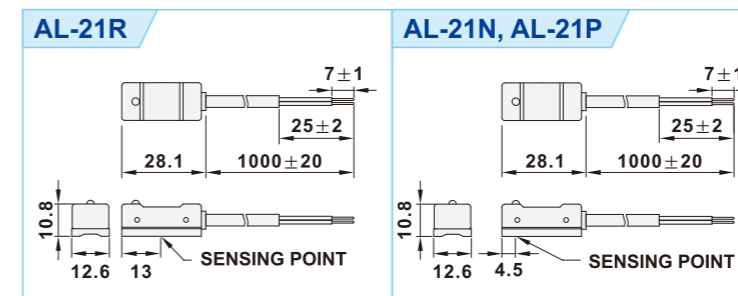

Mounting

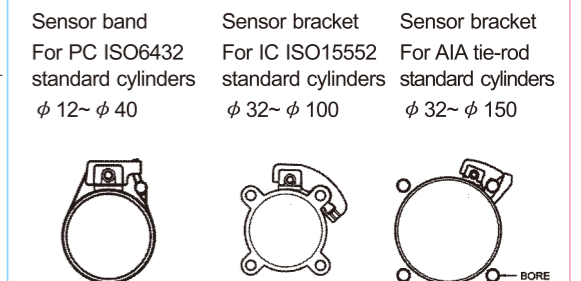

Note

1. Measure standard target: φ 15.5 x φ 8.5 x t5(Anisotropy Rubber Magnet)
2. Sin wave/X.Y.Z 3 Dimensions/3 times each direction/ 11mS Each time.
3. Double amplitude 1.5mm/10 Hz~55Hz~10Hz(Sweep 1min)/X.Y.Z 3 Dimensions/ 1 Hour Each time.

Applicable cylinder

1. Applicable to cylinder JC, JQ, DR, HC, MCFR, JQM, TRC, GC, HYS, HPC, HYC, RCQ, RCA, RCP series.
2. Wire length: 1M,2M,3M.

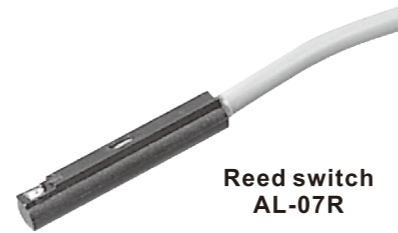

Reed switch
AL-07R

Specifications

Model	AL-07R	AL-07N	AL-07P
Switching logic	SPST Normally open	Solid state output, Normally open	
Output	Reed switch	NPN current sinking	PNP current sourcing
Lead wire type	Horizontal		
Load voltage	5~120 VDC/AC	5~28 VDC	
Load current	100mA Max.	200mA Max.	
Switching rating	10W Max.	6W Max.	
Current consumption	---	20mA Max. @24V	18mA Max. @24V
Voltage drop	2.5V Max. @40mA DC	0.5V Max. @200mA(Resistive load)	
Leakage current	---	0.01mA Max.	
Frequency	200Hz	1000Hz	
Shock	30G	50G	
Vibration	90m/s ² (9G) Double amplitude 1.5mm		
Insulation resistant	DC 500V 100M Ω (Lead wire to case)		
Withstand voltage	AC 1000V (50/60Hz) 1 minute (Lead wire to case)		
CE & Protection IP	EN60947-5-2 IEC529 IP67 (NEMA6)		
Indicator	Red LED		Green LED
Cable	2.6 ϕ , 2C, Gray PVC	2.6 ϕ , 3C, Black PVC	
Temperature range	-10 $^{\circ}$ C ~ 70 $^{\circ}$ C		
Protection circuit	---	Reverse polarity, short circuit, surge suppression	
Wiring	2Wire	3Wire	
Sensor circuit diagram			

Dimensions

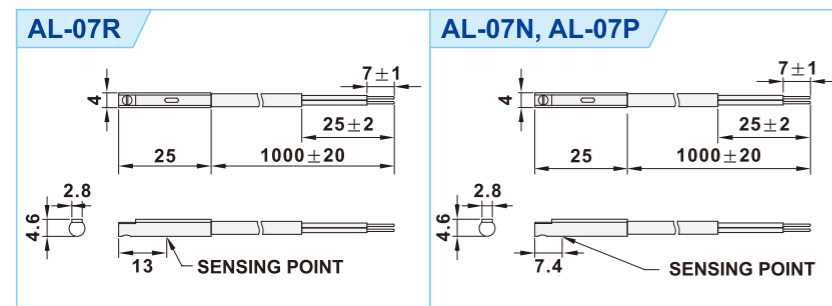

Applicably groove

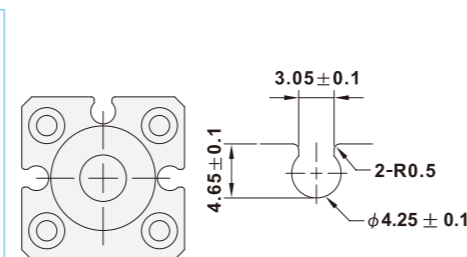

- Note**
1. Measure standard target: ϕ 15.5 x ϕ 8.5 x t5(Anisotropy Rubber Magnet)
 2. Sin wave/X.Y.Z 3 Dimensions/3 times each direction/ 11mS Each time.
 3. Double amplitude 1.5mm/10 Hz~55Hz~10Hz(Sweep 1min)/X.Y.Z 3 Dimensions/ 1 Hour Each time.

Applicable cylinder

1. Applicable to cylinder JC, JQ, DR, JQM, RCA, RCP series.
2. Wire length: 1M,2M,3M.



Reed switch
AL-11R

Specifications

Model	AL-11R	AL-11N	AL-11P
Switching logic	SPST Normally open	Solid state output, Normally open	
Output	Reed switch	NPN current sinking	PNP current sourcing
Lead wire type	Horizontal		
Load voltage	5~240 VDC/AC	5~28 VDC	
Load current	100mA Max.	200mA Max.	
Switching rating	10W Max.	6W Max.	
Current consumption	---	20mA Max. @24V	18mA Max. @24V
Voltage drop	2.5V Max. @40mA DC	0.5V Max. @200mA(Resistive load)	
Leakage current	---	0.01mA Max.	
Frequency	200Hz	1000Hz	
Shock	30G	50G	
Vibration	90m/s ² (9G) Double amplitude 1.5mm		
Insulation resistant	DC 500V 100M Ω (Lead wire to case)		
Withstand voltage	AC 1000V (50/60Hz) 1 minute (Lead wire to case)		
CE & Protection IP	EN60947-5-2 IEC529 IP67 (NEMA6)		
Indicator	Red LED		Green LED
Cable	3.3 ϕ , 2C, Gray PVC	3.3 ϕ , 3C, Black PVC	
Temperature range	-10 $^{\circ}$ C ~ 70 $^{\circ}$ C		
Protection circuit	---	Reverse polarity, short circuit, surge suppression	
Wiring	2Wire	3Wire	
Sensor circuit diagram			

Dimensions

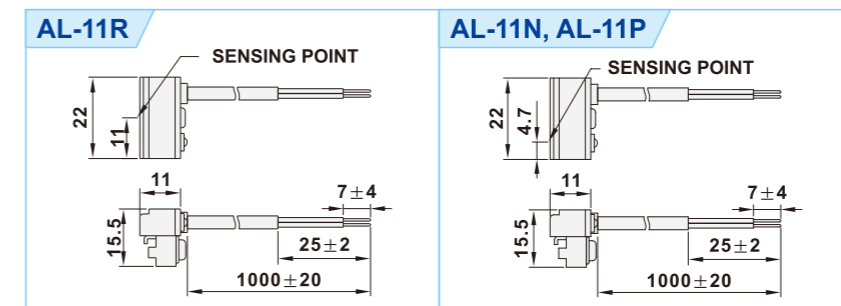

Applicably groove

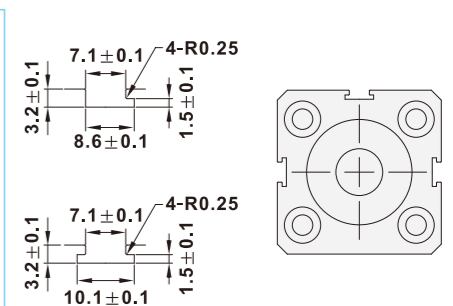

- Note**
1. Measure standard target: ϕ 15.5 x ϕ 8.5 x t5(Anisotropy Rubber Magnet)
 2. Sin wave/X.Y.Z 3 Dimensions/3 times each direction/ 11mS Each time.
 3. Double amplitude 1.5mm/10 Hz~55Hz~10Hz(Sweep 1min)/X.Y.Z 3 Dimensions/ 1 Hour Each time.

■ Applicable cylinder

1. Applicable to cylinder JC, JQ, HC, MCFR, JQM, HPC, HYC, RCA series.
2. Wire length: 1M,2M,3M.



■ Specifications

Model	AL-16R	AL-16N	AL-16P
Switching logic	SPST Normally open	Solid state output, Normally open	
Output	Reed switch	NPN current sinking	PNP current sourcing
Lead wire type	Horizontal		
Load voltage	5~120 VDC/AC	5~28 VDC	
Load current	100mA Max.	200mA Max.	
Switching rating	10W Max.	6W Max.	
Current consumption	---	20mA Max. @24V	18mA Max. @24V
Voltage drop	2.5V Max. @40mA DC	0.5V Max. @200mA(Resistive load)	
Leakage current	---	0.01mA Max.	
Frequency	200Hz	1000Hz	
Shock	30G	50G	
Vibration	90m/s ² (9G) Double amplitude 1.5mm		
Insulation resistant	DC 500V 100MΩ (Lead wire to case)		
Withstand voltage	AC 1000V (50/60Hz) 1 minute (Lead wire to case)		
CE & Protection IP	EN60947-5-2 IEC529 IP67 (NEMA6)		
Indicator	Red LED		Green LED
Cable	2.6 φ , 2C, Gray PVC	2.6 φ , 3C, Black PVC	
Temperature range	-10℃ ~ 70℃		
Protection circuit	---	Reverse polarity, short circuit, surge suppression	
Wiring	2Wire	3Wire	
Sensor circuit diagram			

■ Dimensions

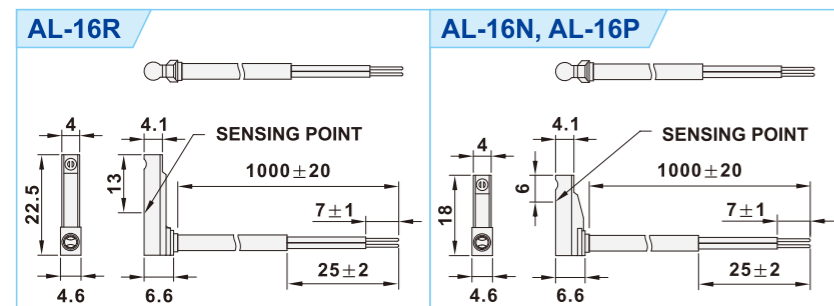

■ Applicably groove

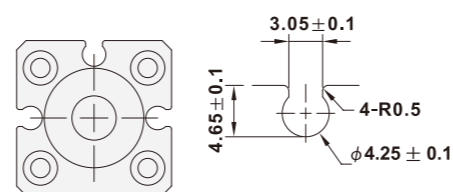

- Note**
1. Measure standard target: φ 15.5 x φ 8.5 x t5(Anisotropy Rubber Magnet)
 2. Sin wave/X.Y.Z 3 Dimensions/3 times each direction/ 11mS Each time.
 3. Double amplitude 1.5mm/10 Hz~55Hz~10Hz(Sweep 1min)/X.Y.Z 3 Dimensions/ 1 Hour Each time.

■ Applicable cylinder

1. Applicable to cylinder HPS, ZS, ZF, ZK series.
2. Wire length: 1M,2M,3M.



■ Specifications

Model	AL-30R	AL-30N	AL-30P
Switching logic	SPST Normally open	Solid state output, Normally open	
Output	Reed switch	NPN current sinking	PNP current sourcing
Lead wire type	Horizontal		
Load voltage	5~240 VDC/AC	5~28 VDC	
Load current	100mA Max.	200mA Max.	
Switching rating	10W Max.	6W Max.	
Current consumption	---	20mA Max. @24V	18mA Max. @24V
Voltage drop	2.5V Max. @40mA DC	0.5V Max. @200mA(Resistive load)	
Leakage current	---	0.01mA Max.	
Frequency	200Hz	1000Hz	
Shock	30G	50G	
Vibration	90m/s ² (9G) Double amplitude 1.5mm		
Insulation resistant	DC 500V 100MΩ (Lead wire to case)		
Withstand voltage	AC 1000V (50/60Hz) 1 minute (Lead wire to case)		
CE & Protection IP	EN60947-5-2 IEC529 IP67 (NEMA6)		
Indicator	Red LED		Green LED
Cable	2.8 φ , 2C, Gray PVC	2.8 φ , 3C, Black PVC	
Temperature range	-10℃ ~ 70℃		
Protection circuit	---	Reverse polarity, short circuit, surge suppression	
Wiring	2Wire	3Wire	
Sensor circuit diagram			

■ Dimensions

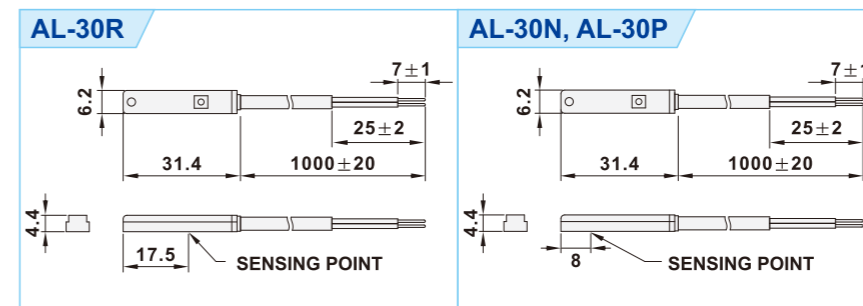

■ Applicably groove

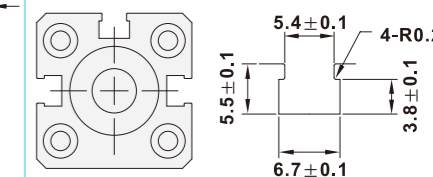

- Note**
1. Measure standard target: φ 15.5 x φ 8.5 x t5(Anisotropy Rubber Magnet)
 2. Sin wave/X.Y.Z 3 Dimensions/3 times each direction/ 11mS Each time.
 3. Double amplitude 1.5mm/10 Hz~55Hz~10Hz(Sweep 1min)/X.Y.Z 3 Dimensions/ 1 Hour Each time.

